

INSTALLATION GUIDE

PIATTO™ COLLECTION WASTE RECEPTACLE INSTALLATION GUIDE (PG 1 of 4)

IMPORTANT: READ THESE INSTRUCTIONS COMPLETELY PRIOR TO BEGINNING INSTALLATION. SAVE FOR FUTURE REFERENCE.

PREPARE FINISHED WALL OPENING (FWO)

Cabinet is designed to fit into FWO with 0.8mm operating clearance on all four (4) edges of door. Door is the same size as the frame flange. See TDS & OM for complete specifications and requirements. There should be adequate in-wall blocking installed prior to FWO side walls completion to receive and hold cabinet mounting screws. Walls of the FWO must be flat, square, straight & plumb. The edges of the FWO at the finished wall are visible and constitute an appearance surface intersection.

Finished Wall Opening (FWO) required is: 440 W x 1018 H x 170mm D minimum

INSTALLATION OF MOUNTING HARDWARE

Place four (4) depth stops in FWO as per diagram on top and bottom of side walls at ceiling & floor lines using 14mm depth stop set gage p/n 1811051152. Depth stop set gage is designed to be held by hand while positioning each depth stop. Ensure front tab is set back from finished wall face by 14mm when securing screws. Install depth stops with four (4) № 10 x 3/4" [M5 x 20] self-threading pan head screws (by others) through slots provided in depth stops (Fig. 1). Retain depth stop set gage tool for future use with additional cabinets.

NOTE

ALL DIM'S INCH [MM]

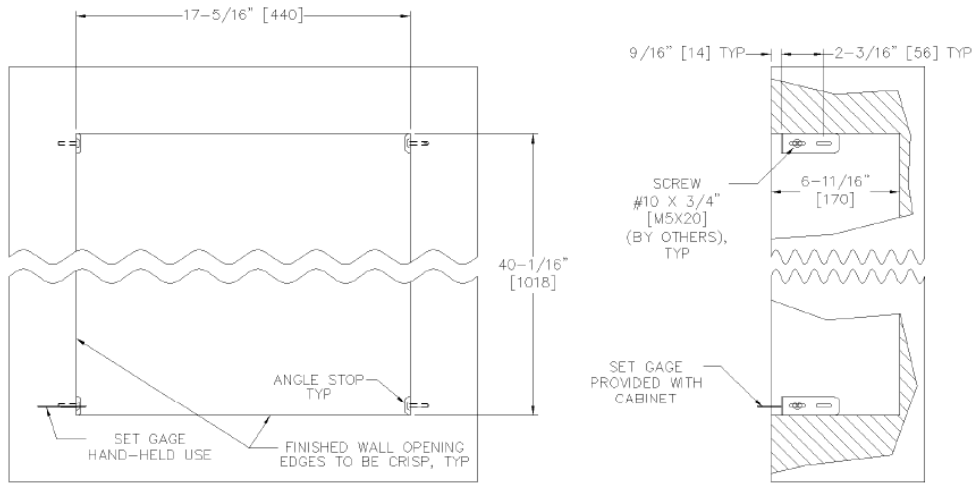
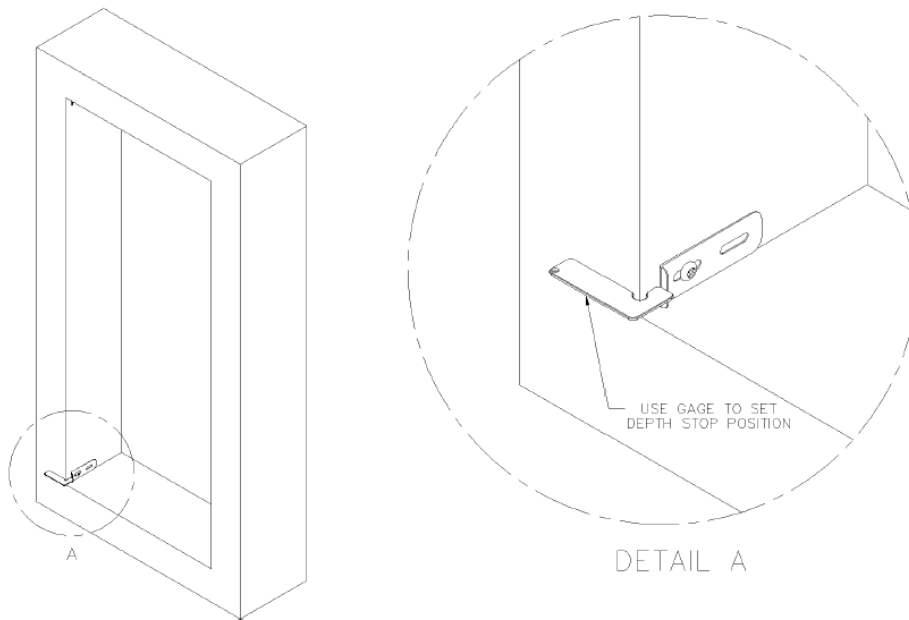

FIG. 1

BREAKOUT VIEW
FWO INTERIOR



INSTALLATION OF CABINET

Remove door from cabinet by lifting hinge clip release levers at back end of hinge arms. Remove WR from cabinet. Move door and WR out of immediate work zone so they are protected from accidental damage. Position cabinet in FWO so flange is tight up against all four (4) depth stop tabs. Maintain 0.8mm operating clearance on all four (4) edges of door (Fig. 2). Top and bottom spacing may be easily maintained by using 22 gage sheet metal (0.8mm thick) shims (by others) temporarily under frame edge at bottom. Side spacing will be self-adjusting and automatically self-centering as four (4) № 10 x 1-1/2" [M5 x 38] self-threading pan head screws (by others) are tightened into the pre-installed blocking through the holes provided in the adjustable shim-less mounting tabs as shown in the diagram.

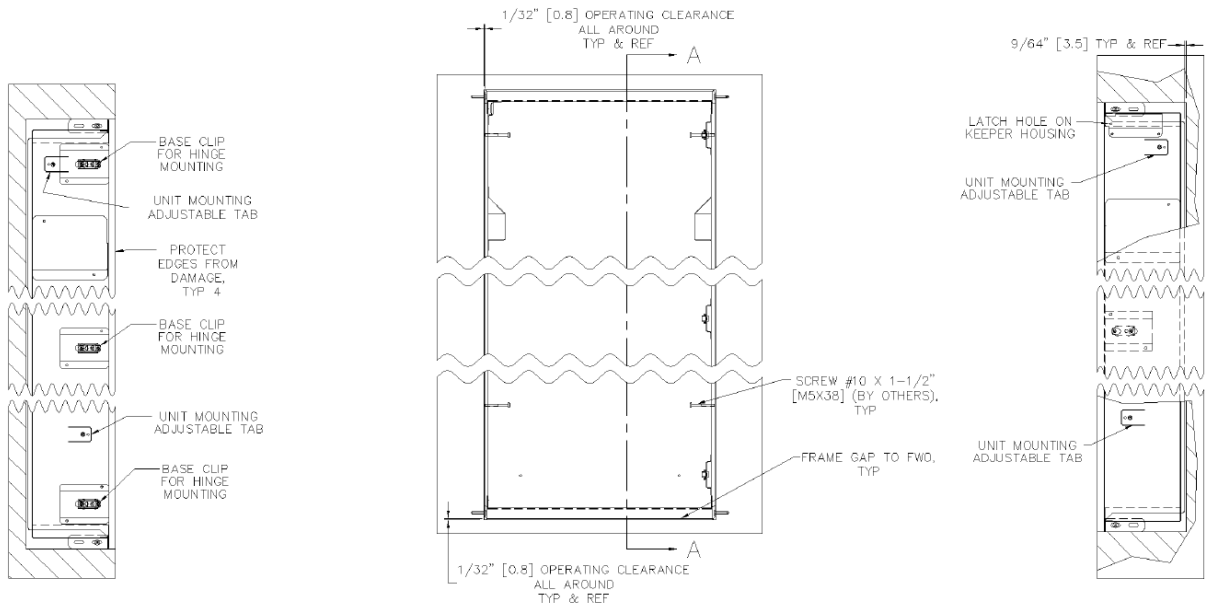

SECTION A-A

FIG. 2

BREAKOUT VIEW
FWO/CABINET INTERIOR

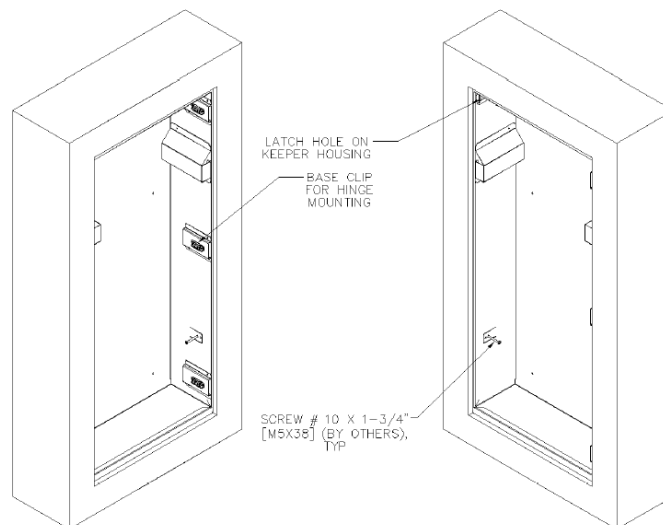

COMPLETION OF INSTALLATION & CABINET REASSEMBLY

Reconnect door hinges to base clips by engaging retainer bar under arm front with hooks on front of clip and then pressing arm against wall until snap-click is heard (Fig. 3). Ensure that door operating clearance and alignment is still correct by adjusting cabinet hinges with adjustment screws provided on arm and base clip if necessary. Ensure that latch engages with keeper when door is closed. Slight hinge readjustment may be required to achieve smooth release and latching operation. Place WR inside cabinet. Retain these instructions and OM for future reference. Clean packaging debris from area.

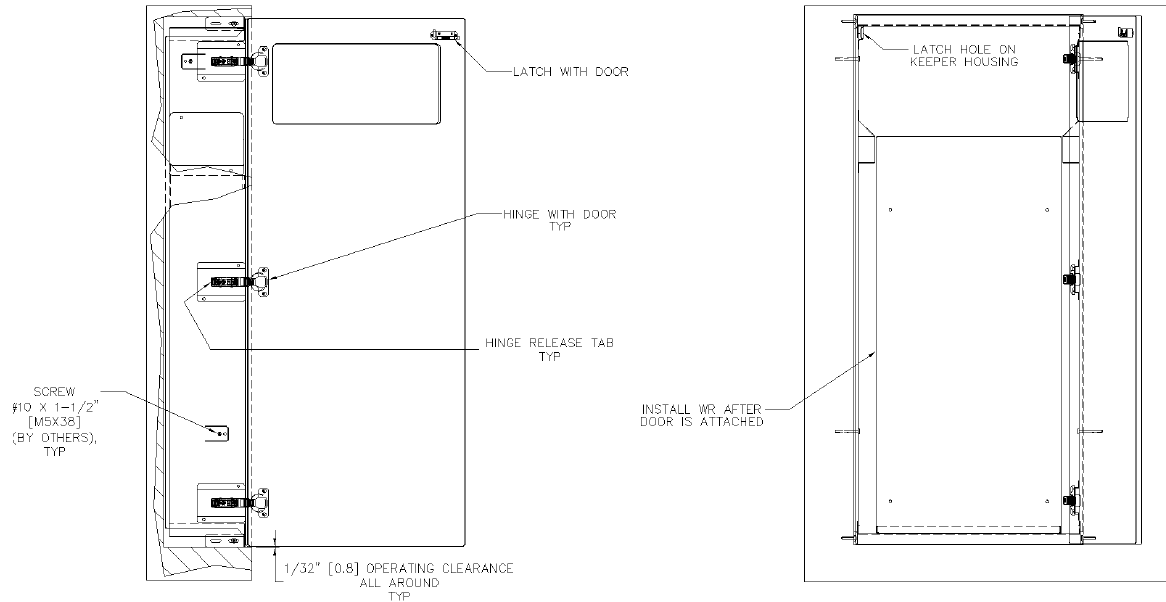

BREAKOUT VIEW
FWO/CABINET INTERIOR

FIG. 3

